

## 2.12 Application of panels as wall linings and partitions

### 2.12.1 Selection of panels for wall linings and partitions

The selection of wood-based panels for wall linings, partitions and ceilings depends on a number of factors of which the most important are:

- Moderate to high resistance to impact and abrasion, especially in certain types of public buildings.
- Good dimensional stability in the presence of seasonal changes in relative humidity of the air.
- The ability to reduce either sound absorption or sound transmission in particular applications. Attention is drawn to the acoustic requirements in Approved Document Part E<sup>54</sup> (with corresponding regulations for Scotland and Northern Ireland): wood-based panels can be used or be complemented by other materials in order to satisfy these requirements.
- The ability to receive a variety of finishes including paints and laminates.
- Satisfying the requirements for fire performance (spread of flame and rate of heat release).

The selection of panels for wall linings, partitions and ceilings based on satisfying the above requirements is given in *Table 2.17*. Their use as wall linings is illustrated in *Figure 2.25*.

#### 2.12.1.1 Decorative linings

Most wood-based panels are suitable for use as internal decorative linings for walls and ceilings, both in new construction and in upgrading and refurbishment, subject to meeting the required surface spread of flame aspect of fire performance.

Because the appearance of panels used internally is usually of prime importance, a large number of proprietary profiled, film-faced or laminate-faced and pre-decorated panels are available.

Where internal linings also act as structural sheathing, strength and durability are of prime importance, with



**Figure 2.25: Wood-based panels used as wall linings at Copenhagen Opera House**

Photo: Coillte Panel Products

appearance and finish of lesser importance, particularly as internal sheathing may also be hidden by other linings.

#### 2.12.1.2 Acoustic linings

Some panels may be used to improve sound absorption within a room, for example fibreboard ceiling tiles ('acoustic tiles'), while other panels may be used to reduce sound transmission between rooms, for example the denser particleboard or cement-bonded particleboard (CBPB), used in conjunction with mineral fibre insulation and other recognised design features for sound resistant partition walls, as shown in *Figure 2.26*.

#### 2.12.1.3 Reaction to fire

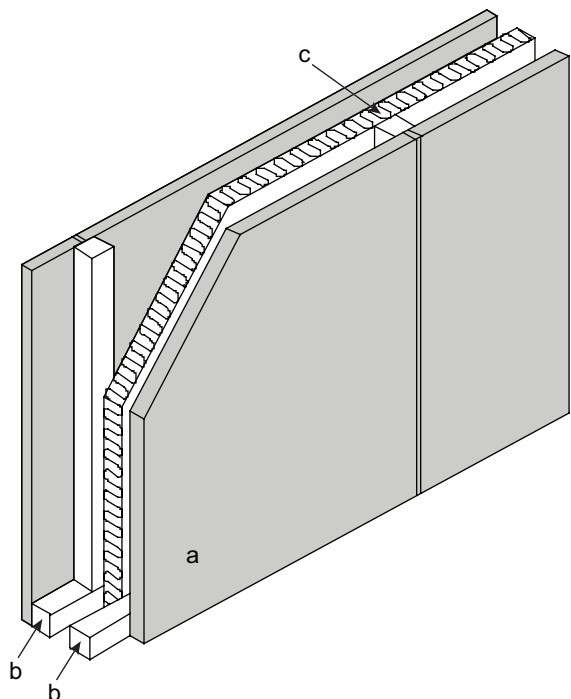
Where timber-based products are exposed internally, fire performance must be considered. According to the UK building regulations both the European (*BS EN 13501-1*) and British (*BS 476-6 & 7*) test methods and classification systems are acceptable, however it should be noted that in a declaration of performance for CE marking purposes the European classification and test method must be used.

Note: Deemed to satisfy (classification without testing) reaction to fire performance of wood-based panels under the European system are given in Table 8 of *EN 13986*. These classes are reproduced in *Annexes 2A to 2G* of *PanelGuide*.

**Table 2.17: Panel grades\* for wall linings and partitions and the reaction to fire Euroclass for specified thicknesses**

Selection	SERVICE CLASS	PLYWOOD EN 636	PARTICLEBOARD EN 312	FLAXBOARD EN 15197	OSB EN 300	MDF EN 622-5	FIBREBOARD EN 622-3,4	CBPB EN 634
Linings	1	636-1	P4	FB3	OSB/2	MDF	MBH	CBPB
Partitions	2	636-2	P5	FB4	OSB/3	MDF.H	MBH.H	CBPB
Ceilings								
Reaction to Fire Class* (pr EN 13501-1)	-	See Annex 2D	See Annex 2A	See Annex 2G	See Annex 2B	See Annex 2E	See Annex 2F	-

\* The Euroclasses for these panels are available without testing based on Table 1 of the Decision of the Commission 2003/43/EC of 2003-01-17 (see *OJEC L13 of 2003-01-18*), as amended by the Decision 2003/593/EC of 2003-08-07 (see *OJEC L201 of 2003-08-08*) and corrected by the Corrigendum (see *OJEC L331 of 2003-02-08*), and further amended by the Decision 2007/348/EC of 2007-05-15 (see *OJEC L131 of 2007/05-23*) may be classified for reaction to fire performance without further testing (CWFT) in specific classes given therein. These Euroclasses are available in the Annexes of *PanelGuide*. The important aspect to note is that there are particular fixing conditions that have to be adhered to in order to obtain the Euroclass without carrying out any further testing.



**Figure 2.26: Internal partition wall with improved acoustic performance**  
a: particleboard or CBPB linings fixed to framing with panel joints staggered  
b: separate wall framing to each face  
c: sound absorbent mineral fibre quilt hung in cavity

Further information on the reaction to fire testing in both the BS and EN systems is provided in PanelGuide Section 2.2.3.

## 2.12.2 Design factors in linings and partitions

### 2.12.2.1 Sizes and thicknesses of panels

Typical panel sizes are 2400 × 1200mm and 2400 × 600mm, with other sizes available to order. Sizes up to 3660mm high are available to allow fabrication of wall panels for increased storey heights. The usual panel width is 1200mm to suit framing centres of 400 and 600mm.

Thickness will depend on the location and purpose of the lining or partition, and on the stiffness and impact resistance required.

### 2.12.2.2 Framing and support centres

#### Non-structural linings and partitions

Conventional framed support is suitable for all panels. Framing should provide support for all panel edges, unless tongued and grooved panels are used.

Intermediate vertical supports should be at the centres shown below depending on panel thickness. For panels of thicknesses <10mm, horizontal supports should be at the same centres as the vertical supports; for panels >10mm, horizontal supports should be at centres no greater than 1200mm.

In order to achieve smooth flat surfaces, maximum stud and batten centres (mm) for panels of given type and thickness should be as given in Table 2.18.

#### Structural sheathing

Where internal linings also act as structural sheathing the recommendations included in Section 2.7 should be followed.

### 2.12.2.3 Secret fixing

Panels may also be secret fixed using interlocking framing battens, as shown in Figure 2.27. Panels so fixed should also have framing battens fixed at the above centres to provide adequate stiffness.

### 2.12.2.4 Joints and jointing

To eliminate visually unacceptable gaps at panel joints due to panel shrinkage, it is recommended that provision is made to mask such gaps by using featured joints or cover strips.

Joints can be featured using gaps or profiled edges, cover battens or metal profiles. Examples are shown in Figure 2.28.

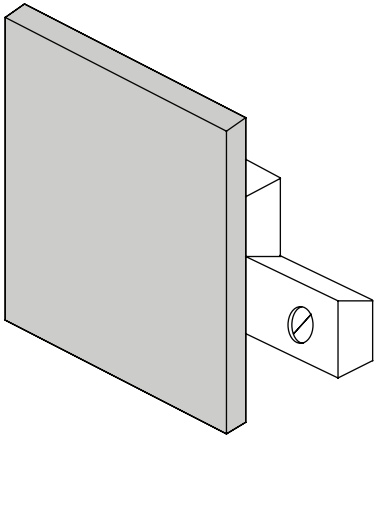
There is a risk of cracking at flush joints due to unavoidable slight movement of panel substrates caused by changes in temperature and humidity.

### 2.12.3 Other considerations

Where wood-based panels are applied to upgrade a solid masonry wall or to provide an internally insulated lining, condensation risk should be considered. A vapour

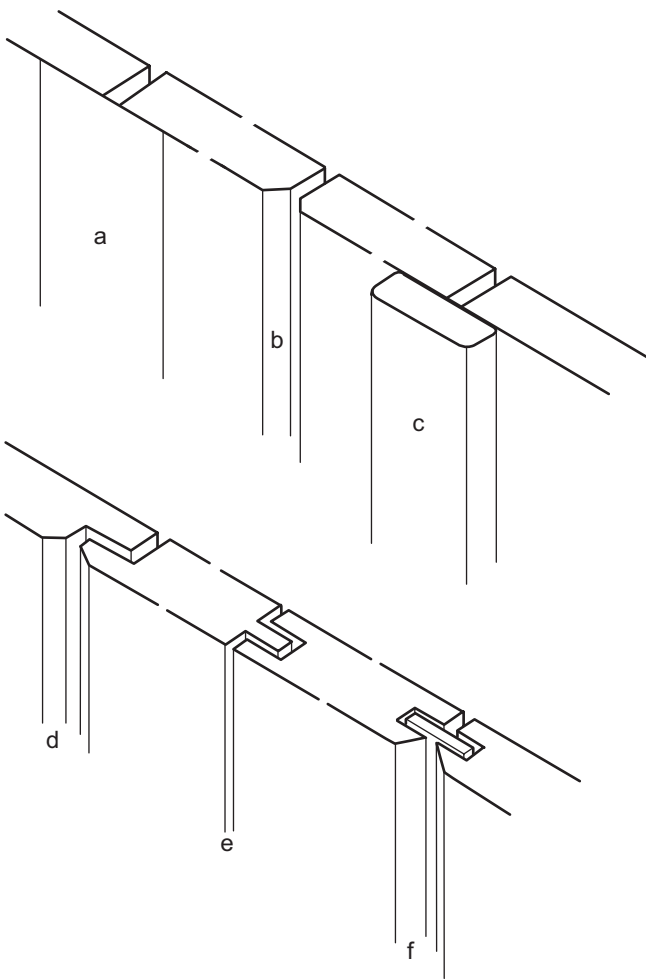
**Table 2.18: Maximum stud and batten centres (mm) for linings and partitions**

Panel types	Panel thickness (mm)						
	3.2	4.8	6.4	9/10	12/13	18/19	>20
Softboard	-	-	-	300	400	600	-
Mediumboard	-	-	400	450	600	600	600
Hardboard	400	500	600	-	-	-	-
MDF	-	-	450	450	600	600	600
CBPB	-	-	450	450	600	600	600
Particleboard	-	-	-	450	600	600	600
Flaxboard	-	-	-	-	600	600	600
OSB	-	-	-	450	600	600	600
Plywood	-	-	-	450	600	600	600

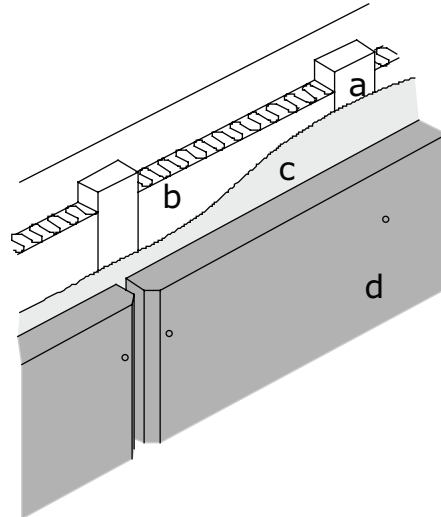


**Figure 2.27: Secret fixing using interlocking battens**  
Upper batten fixed to back of panel and lower batten screwed to wall

control layer should be included on the warm side of the insulation (see *Figure 2.29*). Further information is provided in *BS 5250* which refers to *BS EN ISO 13788* as the method of calculation.



**Figure 2.28 :Typical lining panel joints**  
a: butt joint with scrim tape for plaster skim coat  
b: butted 'V' joint for face fixing  
c: butt joint with timber or metal cover trim  
d: rebated 'V' joint for face fixing  
e: secret fixing tongued and grooved joint  
f: grooved joint with hardwood tongue



**Figure 2.29: Internal lining with thermal insulation**  
a: battens and counterbattens fixed to wall  
b: insulation  
c: vapour control layer – typically 500 gauge polyethylene sheet with lapped joints  
d: lining board

## 2.12.4 Sitework

### 2.12.4.1 Conditioning

It is important that panels are installed at a moisture content close to that which they will achieve in service. Advice on the conditioning of panels is to be found in *PanelGuide Section 4.2.4*.

### 2.12.4.2 Fixing of panels

Panels should be fixed using corrosion resistant nails, staples or screws. Corrosion resistant materials include galvanised or sheradised steel, austenitic stainless steel, phosphor bronze and silicon bronze.

Minimum nail length should be 50mm or 2.5 times the panel thickness, whichever is greater.

Staples should have as wide a crown as possible (11mm minimum), be not less than 15 gauge and not less than 50mm in length.

The frequency and pattern of nailing around the periphery and on intermediate framing should be as shown in *Table 2.19*. Where manufacturer's instructions are supplied with the panels, their recommendations should be followed. To avoid tear out at panel edges, fixings should not be inserted closer to the edges than the minimum distances given.

With the thinner and more flexible panels, to avoid buckling, nailing should commence at the top centre and continue outwards and downwards.

## 2.12.5 Finishes

Panels can be pre-decorated or site-finished with a wide variety of finishes including paints, stains, laminates, wallpaper and other coverings, and tiling. These are described in more detail in *PanelGuide Section 4.7*.

**Table 2.19: Spacing of fixings for linings and partitions**

Panel type	Maximum spacing (mm)		
	Perimeter framing	Intermediate framing	Min edge distance (mm)
Softboard	75	150	12
Mediumboard	150	300	8
MDF	150	300	8
Hardboard	150	300	8
Particleboards	150	300	8
Flaxboard	150	300	8
CBPB	see note below	see note below	see note below
OSB	150	300	8
Plywood	150	300	8

Note: For cement-bonded particleboard recommended nail spacing and edge distances vary with thickness and from manufacturer to manufacturer – examples of nail spacing range from 200 to 400mm on perimeter framing and from 300 to 610mm on intermediate framing; nail edge distance varies from 15mm for panels less than 12mm and 20mm for thicker panels up to 25mm irrespective of thickness. Panels may need to be pre-drilled or fixed with self-drilling screws to avoid splitting. For fixing cement-bonded particleboard it is therefore essential to obtain and follow the manufacturer’s recommendations.

**2.12.6 Reference**

- 1 UK Building Regulations Approved Document E – Resistance to the passage of sound, available at [www.planningportal.gov.uk](http://www.planningportal.gov.uk)



PanelGuide Version 4.1  
ISBN 978-1-909594-21-0

Published in 2014 by the Wood Panel Industries Federation, TRADA Technology Ltd, and the National Panel Products Division (a division of the Timber Trades Federation).

Revised with amendments to Section 2 and Annex 3, 2018

Previous editions are listed in Annex 4 of the PanelGuide

This is a technical book for professionals in the built environment sector. While every effort is made to ensure the accuracy of the advice given, the project partners cannot accept liability for loss or damage however caused arising from the use of the information supplied

All rights reserved. PanelGuide may be downloaded and printed for single use only. You must request the permission of the copyright owners if you wish to extract content from the PanelGuide or use it for any other purpose

© Wood Panel Industries Federation, Warringtonfire Testing and Certification Ltd and the National Panel Products Division (a division of the Timber Trades Federation)

Unless otherwise stated in the caption, all photographs and illustrations included in the Panel Guide are © Wood Panel Industries Federation, Warringtonfire Testing and Certification Ltd and the National Panel Products Division

Revisions to PanelGuide Version 4 contributed by Ian Rochester (WPIF), Vic Kearley (BM TRADA) and Nick Boulton (TTF)

Produced by the publishing team at BM TRADA, the official publisher for the Timber Research and Development Association

Contact details for the PanelGuide project partners are:



Wood Panel Industries Federation  
Autumn Business Park  
Dysart Road  
Grantham  
Lincs  
NG31 7EU  
Tel: 01476 512 381  
Email: [enquiries@wpif.org.uk](mailto:enquiries@wpif.org.uk)  
Website: [www.wpif.org.uk](http://www.wpif.org.uk)

Timber Research and Development  
Association  
Chiltern House  
Stocking Lane  
Hughenden Valley  
High Wycombe  
Bucks  
HP14 4ND  
Tel: 01494 569 603  
Email: [information@trada.co.uk](mailto:information@trada.co.uk)  
Website: [www.trada.co.uk](http://www.trada.co.uk)

National Panel Products Division  
Timber Trades Federation  
The Building Centre  
26 Store Street  
London  
WC1E 7BT  
Tel: 020 3205 0067  
Email: [tff@tff.co.uk](mailto:tff@tff.co.uk)  
Website: [www.tff.co.uk](http://www.tff.co.uk)



Produced by BM TRADA,  
the official publisher for TRADA

Email: [publications@bmtrada.com](mailto:publications@bmtrada.com)  
Website: [www.bmtrada.com](http://www.bmtrada.com)