

2.7 Application of panels in structural wall sheathing

2.7.1 Selection of panels for sheathing

2.7.1.1 Performance considerations

The selection of panel type depends on an overall assessment of wall performance including:

- strength and stability
- whether the sheathing is to be positioned on the inside or the outside of the framing
- durability
- thermal performance
- interstitial condensation risk
- the possible effects of moisture in service
- other components in the wall such as vapour control layers, insulation type and thickness, breather membranes, cavity barriers.

Strength and stability

Sheathing is primarily used to provide racking resistance and stiffness to a framed structure. Plasterboard and other internal lining boards can also contribute to racking resistance.

Sheathing position

In timber framed structures, sheathing is usually applied to the outside of the framing, where it also acts to provide an early dry envelope to the building, and contain and protect any insulation during construction. Permanent weather protection is usually provided by a breather membrane, exterior cladding and a drained and ventilated cavity.

When sheathing is applied internally to the frame, the advantages of early enclosure may be lost but panel properties of strength, durability and abrasion resistance may be used to provide durable linings, for example in agricultural or industrial buildings, subject to the application of an appropriate flame spread treatment if required.

Durability

The durability of wood-based panels depends on:

- the species of timber used
- the adhesives used to bind the veneers, fibres or particles together
- the conditions of use, in particular with regard to wetting and risk of decay.

The heartwood of the species generally used in all wood-based panels typically has a durability rating of 'moderately durable' or 'slightly durable' and commonly includes a high proportion of sapwood, which, for all species, is rated as 'not durable'. The adhesives can have improved moisture resistance for use in humid or exterior applications, dependent on formulation, and can be modified to include other treatments such as fire retardants or insecticides.

Where panels are used as structural sheathing they are generally at risk of wetting during initial erection and over the remainder of the building process until the cladding is complete. In service the panels are likely to be exposed to high humidity on a regular basis but should not be subject to significant direct wetting. These conditions are unlikely to lead to the prolonged excessive moisture contents which can lead to the onset of decay.

Panels however may occasionally be at risk from wetting in service due to building defects. Good design and workmanship, together with the correct type and grade of panel, will reduce the likelihood and consequences of wetting in service.

There are no requirements for preservative treatment of any wood-based structural sheathing used in a conventional timber frame system. Where wood-based panels are used as external sheathing that is exposed to the weather, the specifier should take account of the degree of exposure and the type of cladding when deciding what type of preservative, if any, should be specified.

Thermal performance

Framed walls using fibreboards, OSB, plywood, CBPB or particleboard sheathing are ideally suited for the inclusion of insulation in the space between the studs.

The U-value (thermal transmittance) of a wall depends on its overall construction including sheathing material type, insulation thickness and cladding. Typical examples for timber framed walls (with all voids filled with mineral wool or cellulose fibre insulation, allowing 15% for the framing) and including claddings and linings, could be as follows:

- 90mm studs – 0.42 W/m²k
- 140mm studs – 0.30 W/m²k
- 195mm studs – 0.22 W/m²k

If a well-fitting, rigid foam insulation, with a λ value not greater than 0.02 W/mk is used, these figures become:

- 90mm studs – 0.27 W/m²k
- 140mm studs – 0.19 W/m²k
- 195mm studs – 0.15 W/m²k

Whatever insulation is used, care is required to cut the insulation accurately to fit each cavity or, if blown into a cavity, to ensure that it is uniformly and completely filled. Any gaps could result in cold bridges with potential for surface condensation and significant losses in thermal performance.

These low values make timber frame wall construction ideal for providing excellent thermal performance using proven technology; conventional construction can easily meet Building Regulation requirements.

The use of engineered timber sections instead of solid timber wall studs when used in conjunction with wood-based panels provides space for a greater thickness of

wall insulation resulting in even lower U-values than the examples shown above. Examples of such products would be I-beams, metal web beams or proprietary composite systems.

Moisture in service and condensation risk

When wood-based panels are used as sheathing fixed to the outside of insulated, framed wall panels the internal lining must have higher vapour resistance to control interstitial condensation risk within the wall panel. This is typically obtained by incorporating a separate polyethylene sheet vapour control layer or plasterboard with an integral vapour control layer on the warm (room) side of the insulation. Any wall construction should meet the requirements of *BS 5250*, which now refers to *BS EN ISO 13788* as the method of calculation.

When used as sheathing fixed to the inside of insulated framed wall assemblies, panels with higher vapour resistance, for example OSB as opposed to softboard, may have sufficiently high vapour resistance to act as an adequate vapour check and remove the need for a separate vapour control layer. The outer layers of construction must have a sufficiently low vapour resistance compared to the inner layers to allow the wall to breathe. Condensation risk should be assessed by calculation in accordance with *BS 5250*, which now refers to *BS EN ISO 13788* as the method of calculation.

Breather membrane fixed over the external face of wall assemblies can be used to stop water ingress at panel or wall assembly joints, to protect the panels from wetting during construction, and to improve airtightness. Breather membrane should always be used with particleboard, OSB, plywood and mediumboard sheathing fixed to the outside of framing, but is not needed with impregnated fibreboards or CBPB, unless these materials are used on buildings in areas of severe exposure. The breather membrane should have low vapour resistance (<5.7 MNs/g), to reduce any possible interstitial condensation risk.

Where no breather membrane is used, it is recommended that joints between wall assemblies are taped to stop water ingress and to improve airtightness; panel to panel joints do not need to be taped. Protection against water ingress at floor level also needs to be provided.

Figure 2.14 shows an insulated timber framed wall with wood-based sheathing fixed to the outside of the framing, covered with a breather membrane and clad with brickwork fixed with flexible ties.

2.7.1.2 Panel selection

Given the performance requirements detailed in Section 2.7.1.1, the selection of wood-based panels must be made from the list given in Table 2.9.

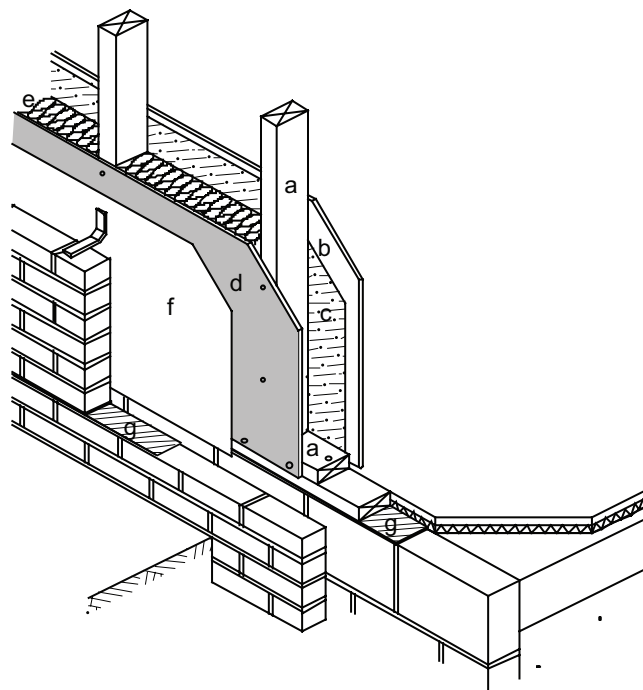

Figure 2.14: Typical timber frame external wall construction

- a: stud framing
- b: internal lining
- c: vapour control layer
- d: sheathing on outside face of wall frame
- e: insulation
- f: breather membrane (when required)
- g: damp proof course

2.7.2 Design of structural sheathing

The various factors to be incorporated in design together with the three alternative design concepts are set out in Section 2.2.

For a particular set of conditions, defined in terms of design, load and environmental conditions, long-term experience and test work has demonstrated compliance of certain designs with the relevant requirements. These designs, or values of racking resistance to be used in design, are deemed to satisfy and the now withdrawn *BS 5268-6-6.1* (Table 2) gives the racking resistance for certain thicknesses of plywood, particleboard, OSB and CBPB.

In those situations where the 'deemed to satisfy' approach is inapplicable, recourse must be made to either designing by prototype testing, or by calculation as set out in Table 2.9 and Section 2.2.1.4

Typical panel sizes are 2400 × 1200mm and 2400 × 600mm, with other sizes available to order. Sizes up to 3660mm high are available to allow fabrication of wall assemblies for increased storey heights, or which can accommodate floor joists. The usual panel width in this case is 1200mm to suit typical framing centres of 400mm and 600mm.

Table 2.9: Panel grades* for timber frame sheathing and the location of design and testing information

Selection	TIMBER FRAME	SERVICE CLASS	PLYWOOD BS EN 636	PARTICLEBOARD BS EN 312	OSB BS EN 300	MDF BS EN 622-5	FIBREBOARD BS EN 622-3,4	CBPB BS EN 634
Sheathing		2	636-2	P5	OSB/3	-	SB.HLS MBH.HLS1 MBH.LS2 HB.HLA2	CBPB
Design by deemed to satisfy	✓	'Deemed to satisfy' performance values for racking resistance are given in BS 5268-6-6.1 (Table 2) for Category 1 panels such as plywood, particleboard, OSB and CBPB. Although this Standard has been withdrawn by BSI, it is still in regular use at present						
or	✓	Test using BS EN 594 and BS EN 596. Satisfy requirements in BS EN 12871. Design using BS EN 1995-1-1 (Eurocode 5) in conjunction with PD 6693-1						
Design by performance testing	or	Test using BS EN 594 and BS EN 596. Satisfy the requirements in BS 5268-6-6.1. Design using BS 5268-6-6.1						
or	✓	Test using BS EN 594 and BS EN 596. Satisfy requirements in BS EN 12871. Design using BS EN 1995-1-1 (Eurocode 5) in conjunction with PD 6693-1						
Design by calculation	or	Test using BS EN 594 and BS EN 596. Satisfy the requirements in BS 5268-6-6.1. Design using BS 5268-6-6.1						
Guidance on application	✓	Guidance on the use of load-bearing panels in sheathing is given in DD CEN/TS 12872 and in BS 5268-6-6.1						

* The table provides the minimum grade of panel that satisfies the particular set of requirements: panels of higher quality may be substituted, and their selection may result in a reduction in required thickness. Although all the panels meeting the grade specifications will satisfy a particular set of requirements, the level of performance of different brands of these panels may vary considerably; some may even be endowed with high levels of properties not directly covered by the table.

2.7.3 Sitework

2.7.3.1 Conditioning

It is important that in the construction of wall units, either on site or in the factory, individual panels are fixed at a moisture content close to that which they will achieve in service. Advice on the conditioning of panels is to be found in PanelGuide *Section 4.2.4*.

2.7.3.2 Wall assembly

Wood-based panels can be used as sheathing in wall assemblies made either on site or off site, or in 'stick-built' construction assembled on site.

2.7.3.3 Planning and cutting

Stud spacing shall be related to the sheathing and lining board widths, for ease of fixing and to avoid cutting panels unnecessarily, and are commonly at 400mm or 600mm centres. Openings can be formed by cutting panels to fit around the framed openings or by cutting the required opening in a panel already fixed to the opening framing. Such openings must be framed and need to be accounted for in the design calculations.

2.7.3.4 Assembly

Sheathing, except softboard fixed to the outside of framing, should have gaps of 3mm between adjacent panels to accommodate possible expansion due to moisture content increase. Softboard should be tightly butted. Sheathing fixed to the inside of framing should be tightly butted except in the case of OSB.

All panels should have all edges supported by and fixed to a framing member with minimum bearing of 18mm for the panel edge. At their edges, panels should normally be flush with framing member edges, to ensure adequate anchorage and give protection to the framing from the weather. It is good practice to tape or gasket panel joints where there is no breather membrane.

2.7.3.5 Fixing

Panels should be fixed using corrosion resistant nails, staples or screws. Corrosion resistant materials include galvanised or sheradised steel, austenitic stainless steel, phosphor bronze and silicon bronze. NHBC and Foundation 15 have particular requirements for the material specification for nails and staples.

Minimum nail length should be 50mm or 2.5 times the panel thickness, whichever is greater. The minimum fixing diameter should be 0.16 times the panel thickness.

Staples should have as wide a crown as possible (11mm minimum), be not less than 15 gauge and not less than 50mm in length.

The frequency and pattern of nailing around the periphery and on intermediate studs is given in *Table 2.10* and shown in *Figure 2.15*, and this should be followed unless structural calculations or testing can provide an alternative nailing schedule. Where manufacturer's instructions are supplied with the panels, their recommendations should be followed. To avoid tear out at panel edges, fixings should not be inserted closer to the edges than the minimum distances given in *Table 2.10*, unless this is supported by test data.

With the thinner and more flexible panels, to avoid buckling, nailing should commence at the top centre and continue outwards and downwards.

2.7.3.6 Handling and storage of fabricated wall assemblies

Where panels are used to form structural wall assemblies, which are then transported to site from the point of fabrication, it is recommended that the following precautions are taken during storage and erection of the wall

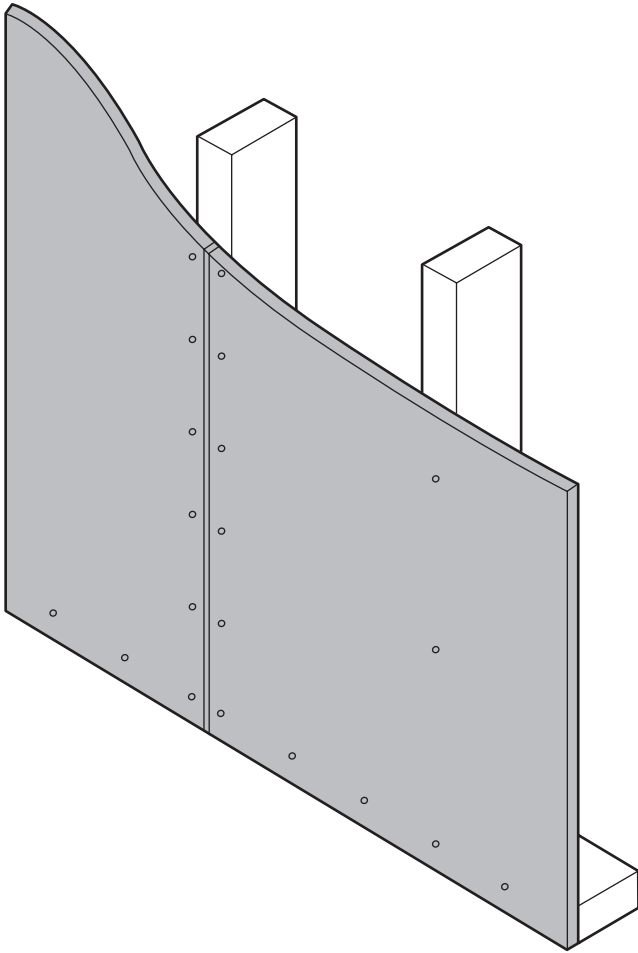

Figure 2.15: Typical sheathing fixings

Minimum edge distance 8mm. Centres of intermediate fixings are generally twice the perimeter fixing centres (see *Table 2.10*)

assemblies, so that they reach site and are installed in the best possible condition.

Transport

- Protect with waterproof coverings during transport.
- Ensure finished panels are fully supported.
- Provide edge protection to avoid banding or strapping damaging panel edges.

Storage

- Store wall assemblies on raised bearers to prevent contact with the ground or with vegetation, and sufficiently clear of the ground to avoid any potential splashing from water on the ground.
- Ensure wall assemblies are fully supported to prevent distortion, sagging or twisting.

Table 2.10: Spacings of fixings in sheathing

Panel type	Maximum spacings (mm)		
	Perimeter framing	Intermediate framing	Min edge distance (mm)
Softboard	75	150	8
Mediumboard	150	300	8
Hardboard	150	300	9
Particleboard	150	300	8
Cement-bonded particleboard*	150	300	8
OSB	150	300	8
Plywood	150	300	8

* Panels may need to be pre-drilled or fixed with self-drilling screws to avoid splitting

- Wall assemblies may be stored horizontally or vertically. If stored horizontally, place them with the sheathing face uppermost to avoid collection of water within the panels.
- Protect wall assemblies from rain saturation.
- Where panels are delivered to site with insulation and internal linings fitted, ensure that the panels are protected from rain at all stages of transport, storage and construction.

Handling

- Take care during lifting to avoid distortion/twisting of panels, straining of fixings and joints, and damage to edges.
- When panels are lifted by crane, use guide ropes to stop excessive sway and to assist in locating panels.
- Ensure panels are not used as 'ladders' to provide temporary access to upper storeys.

2.7.3.7 Erection of wall assemblies

Wall assembly framing should only be notched, cut or drilled if carried out in accordance with the recommendations of the timber frame manufacturer. These recommendations should normally be based on *Eurocode 5* or *BS 5268-2*. Small holes or openings through the sheathing should be framed to support all edges.

Panel to panel nailing and on-site nailing of sheathing to framing should follow nailing schedules.

If wall assemblies are damaged during storage, handling or erection, it is recommended that damaged panels are not patched over but are either partly replaced using appropriate framing to support cut panel edges or completely replaced. In the case of serious damage, consult a qualified structural engineer.

Framed wall assemblies with fibreboard, particleboard, CBPB, OSB or plywood sheathing can be clad with a range of materials including brickwork, render on stainless steel mesh, rendered blockwork, tiles or slates, profiled metal sheet, timber boarding, exterior fibreboard and particleboard cladding, or proprietary wood panel products.

All claddings should incorporate a ventilated and drained cavity between the cladding and the outside of the wall assemblies (see *Figure 2.14*).

Battens for tile-hanging or other claddings should be fixed through the sheathing to the framing, not to the sheathing alone. Where horizontal battens are fixed for tiles or slates, they should be fixed to vertical battens nailed through to the studs. The vertical battens should form a drained and ventilated cavity.

Wall ties for brick or block cladding should be strip ties of austenitic stainless steel, phosphor bronze, or silicon bronze, and should be flexible to allow for differential movement between the structure and the cladding. The ties should be fixed through external sheathing to the stud framing.

CBPB, tempered hardboard, exterior structural plywood and OSB may also be used to act as combined sheathing and cladding in appropriate situations. Careful consideration should be given to joint details and any paint or finishing systems. Where panels are used as combined sheathing/cladding on insulated wall panels, the condensation risk of any paint or finishing system needs to be carefully assessed.

PanelGuide Version 4.1
ISBN 978-1-909594-21-0

Published in 2014 by the Wood Panel Industries Federation, TRADA Technology Ltd, and the National Panel Products Division (a division of the Timber Trades Federation).

Revised with amendments to Section 2 and Annex 3, 2018

Previous editions are listed in Annex 4 of the PanelGuide

This is a technical book for professionals in the built environment sector. While every effort is made to ensure the accuracy of the advice given, the project partners cannot accept liability for loss or damage however caused arising from the use of the information supplied

All rights reserved. PanelGuide may be downloaded and printed for single use only. You must request the permission of the copyright owners if you wish to extract content from the PanelGuide or use it for any other purpose

© Wood Panel Industries Federation, Warringtonfire Testing and Certification Ltd and the National Panel Products Division (a division of the Timber Trades Federation)

Unless otherwise stated in the caption, all photographs and illustrations included in the Panel Guide are © Wood Panel Industries Federation, Warringtonfire Testing and Certification Ltd and the National Panel Products Division

Revisions to PanelGuide Version 4 contributed by Ian Rochester (WPIF), Vic Kearley (BM TRADA) and Nick Boulton (TTF)

Produced by the publishing team at BM TRADA, the official publisher for the Timber Research and Development Association

Contact details for the PanelGuide project partners are:



Wood Panel Industries Federation
Autumn Business Park
Dysart Road
Grantham
Lincs
NG31 7EU
Tel: 01476 512 381
Email: enquiries@wpif.org.uk
Website: www.wpif.org.uk

Timber Research and Development
Association
Chiltern House
Stocking Lane
Hughenden Valley
High Wycombe
Bucks
HP14 4ND
Tel: 01494 569 603
Email: information@trada.co.uk
Website: www.trada.co.uk

National Panel Products Division
Timber Trades Federation
The Building Centre
26 Store Street
London
WC1E 7BT
Tel: 020 3205 0067
Email: tff@tff.co.uk
Website: www.tff.co.uk



Produced by BM TRADA,
the official publisher for TRADA

Email: publications@bmtrada.com
Website: www.bmtrada.com